

# Concrete pump

# BSA 1005 -E

Output up to 59 m<sup>3</sup>/h  
 Delivery pressure up to 55 bar

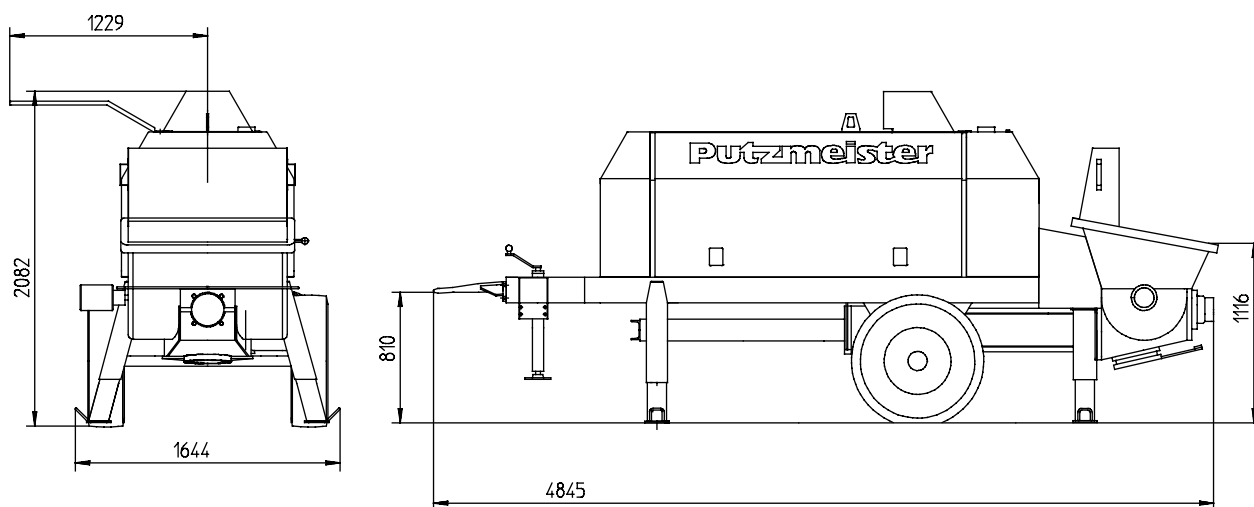

Note: Standard version. Dimensions and weights depend on equipment.

## Performance diagram

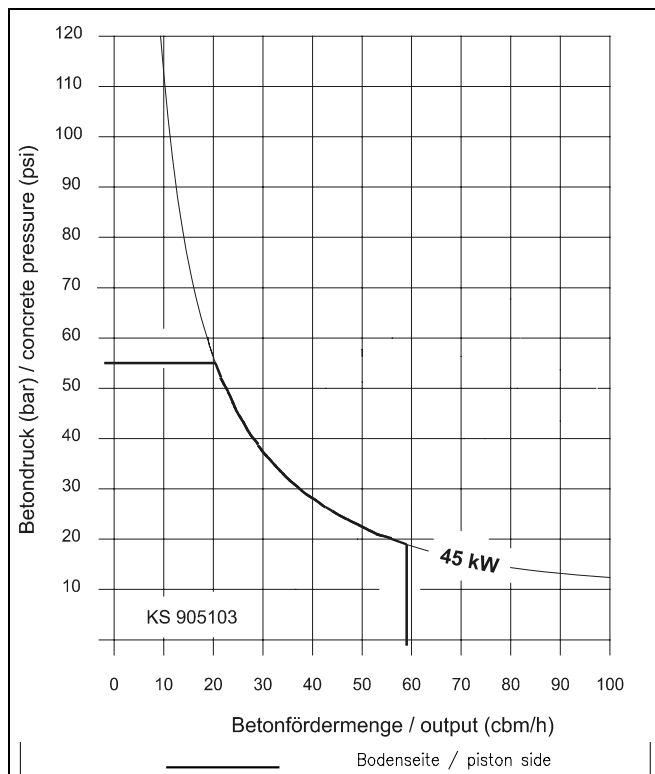

## Technical data for concrete pump

Model		BSA 1005 -E
Material number		101265.003
Output	m <sup>3</sup> /h	59
Delivery pressure	bar	55
Delivery cylinder	Ø mm	180
Delivery cyl. stroke	mm	1000
Strokes / minute		41
Engine power	kW	45 *
Hopper		RS 400
Capacity	l	approx. 350
Filling height	m	1.1
Transfer tube		S 1812
Pressure connection		5.5"
Control system		fully hydraulic (VHS)
Weight	kg	2500

\* Electric motor with 50 Hz.  
 All data maximum theoretical

Alterations due to technical progress reserved.  
 Please see quotation for exact serial delivery scope.

## Hopper with transfer tube

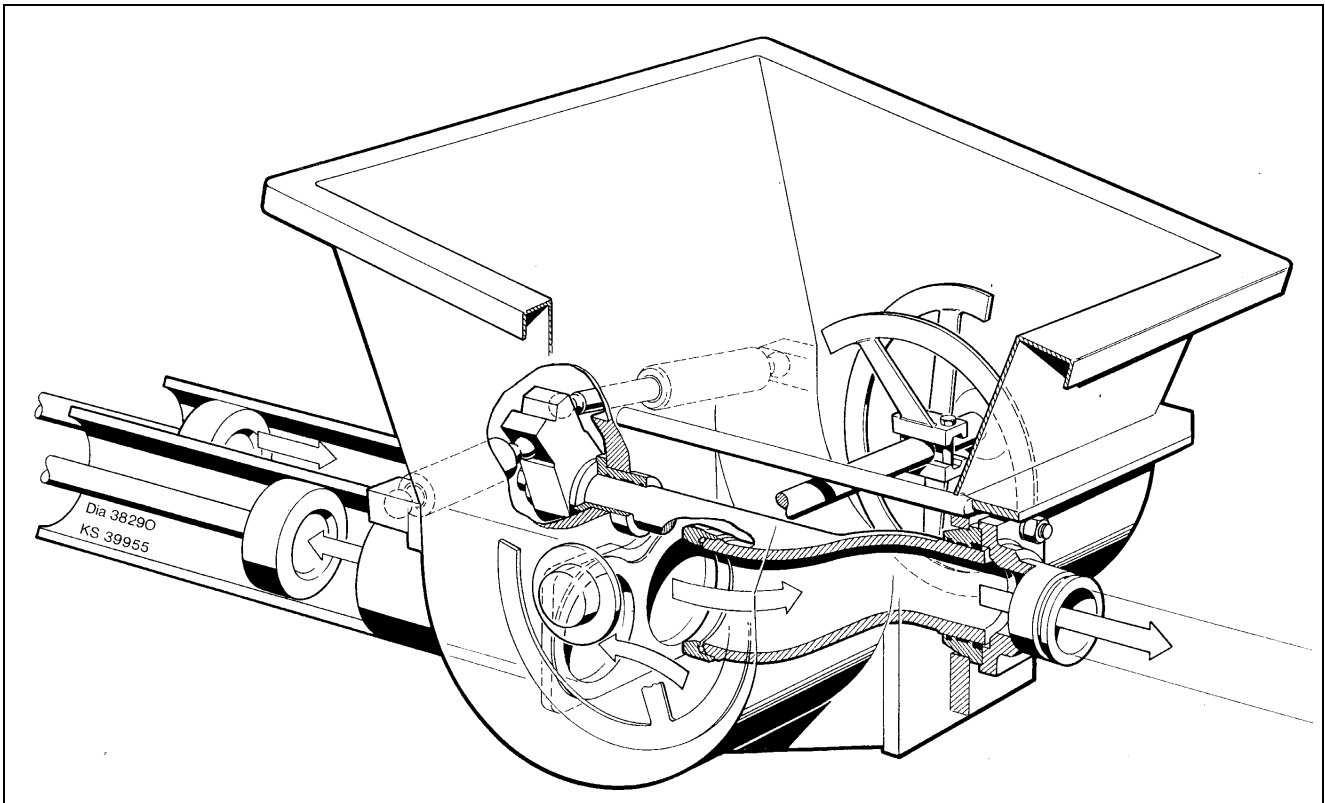

### Delivery scope

- basic frame with hood
- CE-Kit with agitator safety switch off
- central lubrication strip hopper
- cleaning accessories
- concrete hopper with agitator
- coupling ring (DIN)
- drive electric 45 KW
- grill 70 mm
- operating manuals 2x cert. and spare part lists
- painting: MB 1227 chrome yellow
- set of tools
- side flaps 2x
- splash guard
- square outriggers 4x mech. 15°-slanging
- support leg on towbar
- trailer F 8, can be driven on job site

### Optional extras

On request