

Concrete pump

BSA 1005 SV -D

Output up to 47 m³/h
 Delivery pressure up to 55 bar

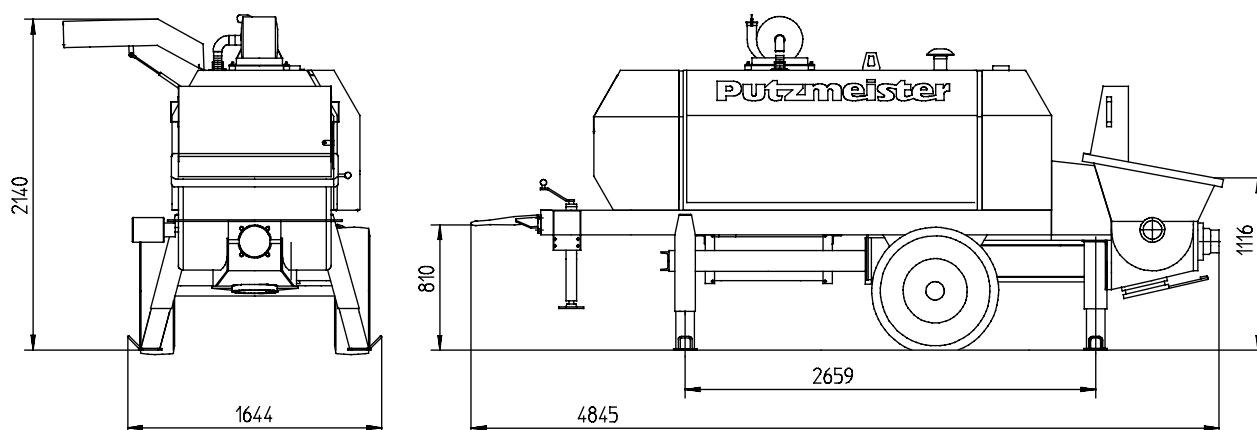

Note: Standard version. Dimensions and weights depend on equipment.

Performance diagram

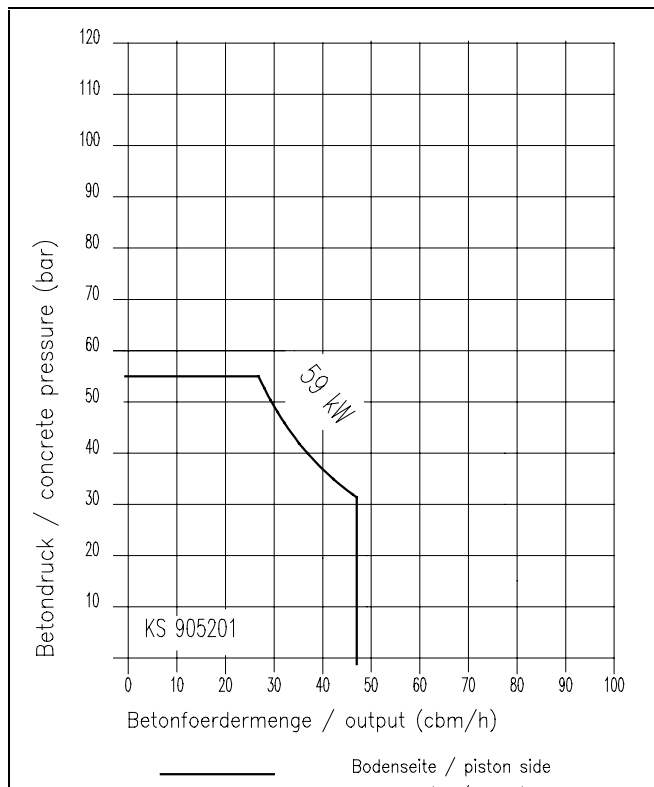

Technical data for concrete pump

| Model | | BSA 1005 SV -D |
|----------------------|-------------------|-----------------------|
| Material number | | 101262.006 |
| Output | m ³ /h | 47 |
| Delivery pressure | bar | 55 |
| Delivery cylinder | Ø mm | 180 |
| Delivery cyl. stroke | mm | 1000 |
| Strokes / minute | | 31 |
| Engine power | kW | 59 |
| Hopper | | RS 400 |
| Capacity | l | approx. 350 |
| Filling height | m | 1.1 |
| Transfer tube | | S 1812 |
| Pressure connection | | 5.5" |
| Control system | | fully hydraulic (VHS) |
| Weight | kg | 3000 |

All data maximum theoretical

Alterations due to technical progress reserved.
 Please see quotation for exact serial delivery scope.

Hopper with transfer tube

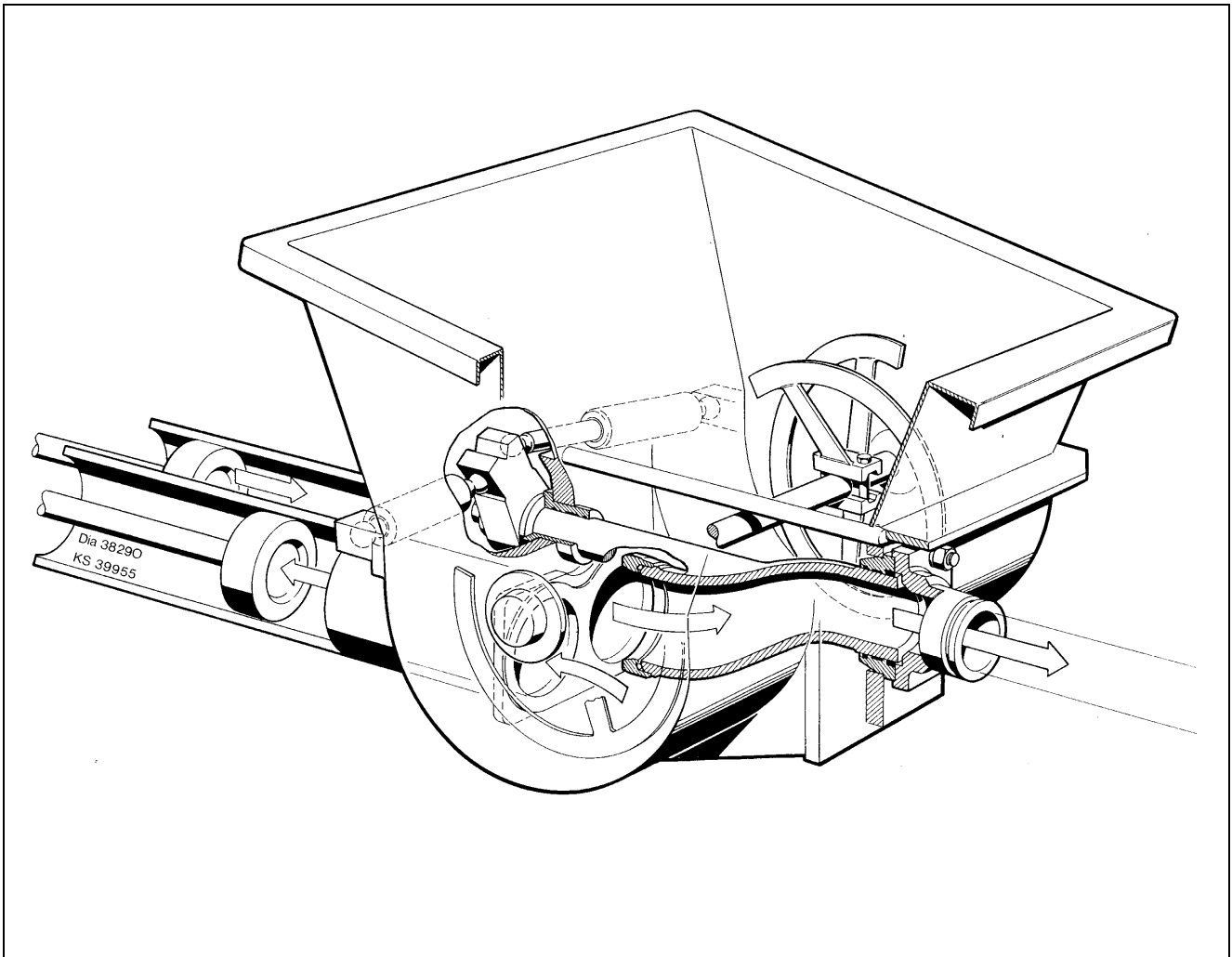

Delivery scope

- CE-Kit with agitator safety switch off
- central lubrication strip hopper
- cleaning accessories
- concrete hopper with agitator
- coupling ring (DIN)
- drive diesel, Deutz 59 KW
- grill 70 mm
- operating manuals 2x cert. and spare part lists
- painting: MB 1227 chrome yellow
- set of tools
- side flaps 2x
- sound proofed version (CEN) < 80dBA
- splash guard
- square outriggers 4x mech. 15°-slanging
- support leg on towbar
- trailer F 8, can be driven on job site
- VHSZE with remote control 5m cable

Optional extras

On request